

General purpose robot
MOTOMAN-HP6
MOTOMAN-HP6-10

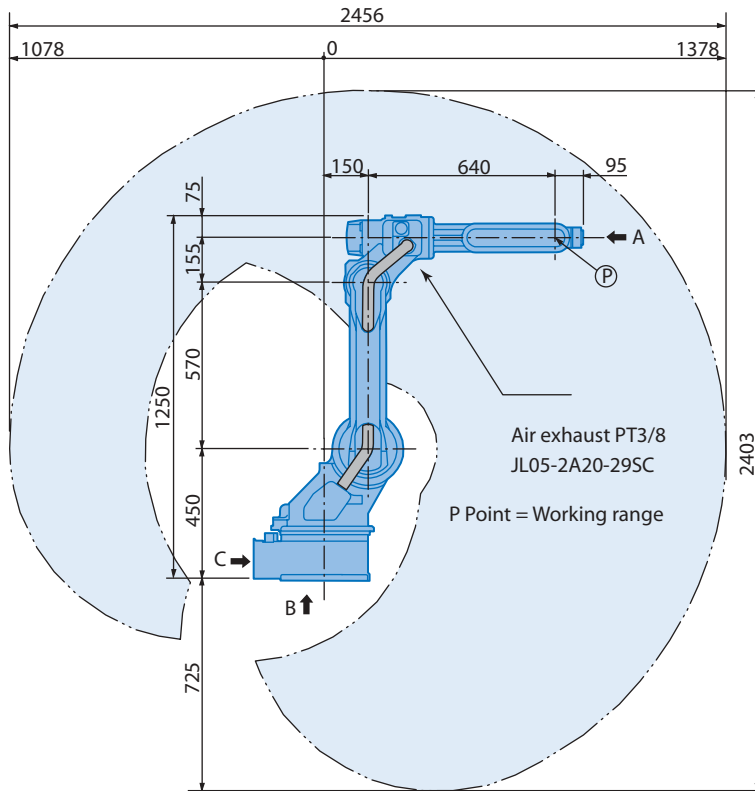

MOTOMAN-HP6



View A

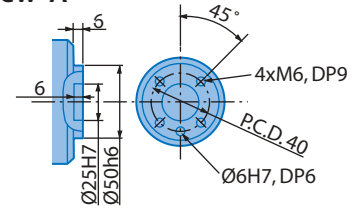

View B

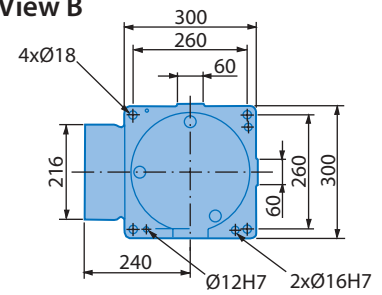

View C

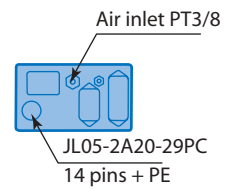

Maximum payload

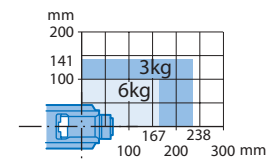

Note

These dimensions are for reference only. Please request detail drawings for all design or engineering requirements.

Technical Specification for MOTOMAN-HP6

Controlled axis	6	Axis	Motion range	Maximum speed	Allowable moment	Allowable inertia
Payload	6 kg					
Repeatability	±0.08 mm	S	±170°	150°/s	-	-
Weight	130 kg	L	+155°, -90°	160°/s	-	-
Power requirements	1.5 kVA	U	+250°, -175°	170°/s	-	-
Mounting positions	Floor, wall ¹⁾ and ceiling	R	±180°	340°/s	11.8 Nm	0.24 kg·m ²
Wrist unit protection class	N.C. ²⁾	B	+225°, -45°	340°/s	9.8 Nm	0.17 kg·m ²
Robot body protection class	N.C. ²⁾	T	±360°	520°/s	5.9 Nm	0.06 kg·m ²
Ambient conditions	0 to +45°C, 20-80% RH					

¹⁾ S-axis limitations

²⁾ Not classified for standard version. Optional IP-class pending.

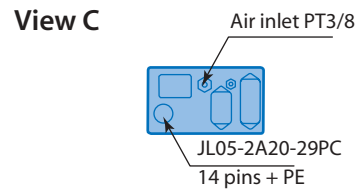
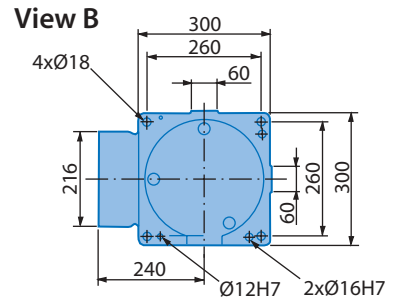
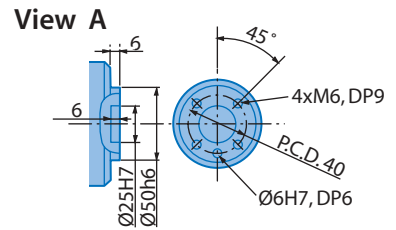
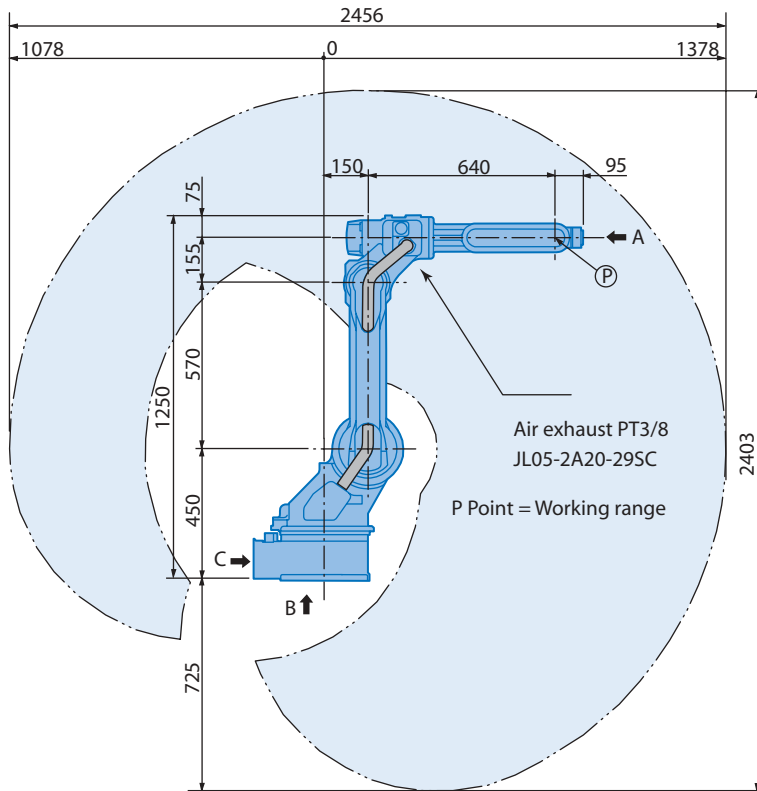

Maximum payload

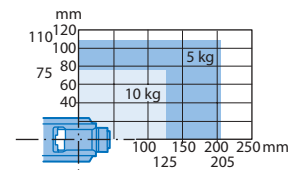

Note

These dimensions are for reference only.
Please request detail drawings for all design or engineering requirements.

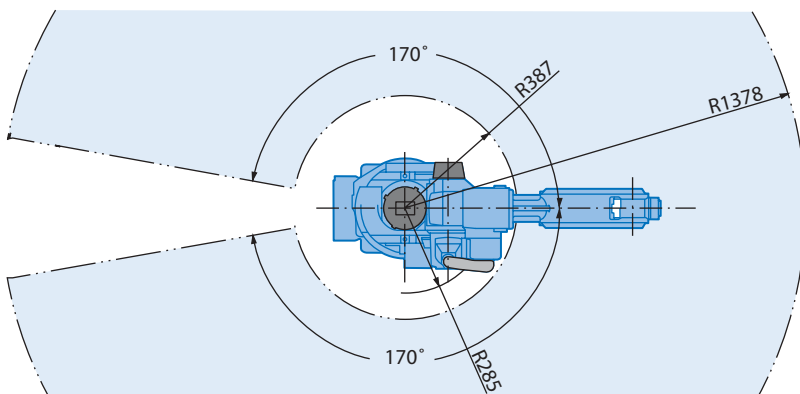

Technical Specification for MOTOMAN-HP6-10

Controlled axis	6	Axis	Motion range	Maximum speed	Allowable moment	Allowable inertia
Payload	10 kg					
Repeatability	±0.08 mm	S	±170°	120°/s	-	-
Weight	130 kg	L	+155°, -90°	130°/s	-	-
Power requirements	1.5 kVA	U	+250°, -175°	135°/s	-	-
Mounting positions	Floor, wall ¹⁾ and ceiling	R	±180°	270°/s	12.2 Nm	0.24 kg·m ²
Wrist unit protection class	N.C. ²⁾	B	+225°, -45°	270°/s	14.2 Nm	0.21 kg·m ²
Robot body protection class	N.C. ²⁾	T	±360°	400°/s	7.3 Nm	0.06 kg·m ²
Ambient conditions	0 to +45°C, 20-80% RH					

¹⁾ S-axis limitations

²⁾ Not classified for standard version. Optional IP-class pending.

Motoman offices and representatives near you

Motoman European headquarters

SE Motoman Robotics Europe AB
Kalmar +46-480-417800

Motoman company group

DE Motoman Robotec GmbH
Allershausen +49-8166-90-0
Motoman Robotec GmbH
Frankfurt +49-6173-6077-30

DK Motoman Robotics Europe AB
Tilst +45 7022 2477

ES Motoman Robotics Iberica S.L.
Barcelona +34-93-6303478

FI Motoman Robotics Finland Oy
Turku +358-40300600

FR Motoman Robotics S.A.
Nantes +33-2-40131919

GB Motoman Robotics UK Ltd
Banbury +44-1295-272755

IT Motoman Robotics Italia SRL
Modena +39-059-280496

PT Motoman Robotics Iberica S.L.
Aveiro +351-234-943 900

SI Ristro d.o.o.
Ribnica +386-61-861113

Distributors

CH Messer SAG
Dällikon +41-18-471717

GR Kouvalias Industrial Robots
Kallithea +30-1-95892436

HU Rehm Hegesztéstechnika Kft
Budapest +36-30-9510065

IL KNT Engineering Ltd
Kfar Azar +972-39231944

NO Optimove as
Lierstranda +47-32240600

PL Roboprojekt Boc Sp.z.o.o.
Siewierz +48-326728952

TR Teknodrom Robotik Otomasyon Ltd.
Gebze, Kocaeli +0090-2626443444

ZA Robotic Systems SA PTY Ltd
Johannesburg +27-11-608318



European Headquarters

Motoman Robotics Europe AB
Franska vägen 10, Kalmar
Box 4004 • SE-390 04 Kalmar, SWEDEN
Phone: +46 (0)480-417 800
Fax: +46-(0)480-417 999

Production unit

Motoman Robotics Europe AB
Verkstadsgatan 2, Torsås
Box 504 • SE-385 25 Torsås, SWEDEN
Phone: +46 (0)480-417 800
Fax: +46-(0)486-414 10

www.motoman.se



Technical data may be subject to change without previous notice · Motoman Robotics Europe AB 2005 · Reg. No. MRS6203.GB.1.L

